



WB-AT ACOUSTICAL TILE ACCESS DOOR

The WB-AT Acoustical Tile Access Door is a ceiling precision door that provides a virtually concealed installation, keeping acoustical surfaces intact while contributing to sound control and better appearance. Door is recessed to accept up to 1" thick acoustical tile. Each door comes complete with grommets.

FEATURES

Door	16 ga. cold rolled steel. Door is recessed to accept up to 1" acoustical tile.
Box Return Frame	16 ga. cold rolled steel
Hinge	Continuous piano hinge opens 180 degrees, will be placed on long side of door unless otherwise requested.
Latches	Flush, stainless steel cam operated with screwdriver. Latches positioned opposite hinge as well as top and bottom on larger sizes.
Finish	White powder coat finish
Options (at extra cost)	Medium barrel cylinder lock

Model No.	A x B Door Size	Hinges	Cam Latch	Shipping Weight (lbs)
WB-AT 12x12	12" x 12"	1	1	8
WB-AT 12x24	12" x 24"	1	2	13
WB-AT 18x18	18" x 18"	1	3	15
WB-AT 24x24	24" x 24"	1	3	25
WB-AT 24x36	24" x 36"	1	5	33

Rough ceiling opening = door size + 1/4"



WB-AT

DIMENSIONS

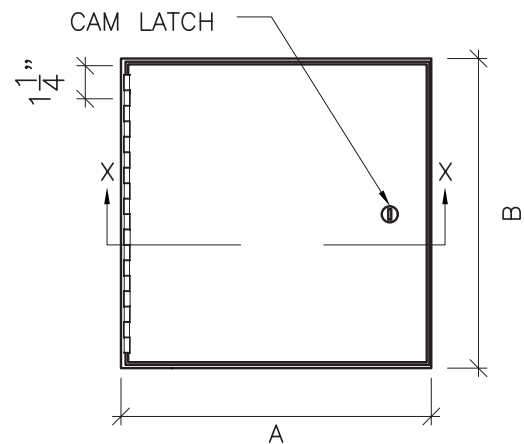

Elevation

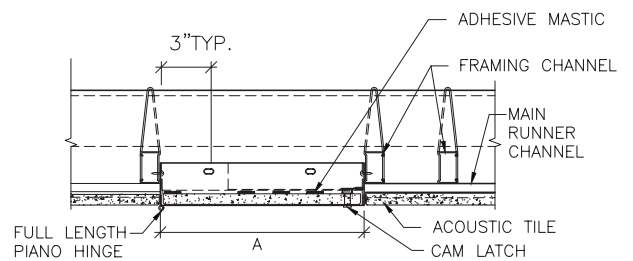

Section Detail